

Ersatzteilliste - Liste des pièces de rechange - Reservdelislista
Spare Parts List

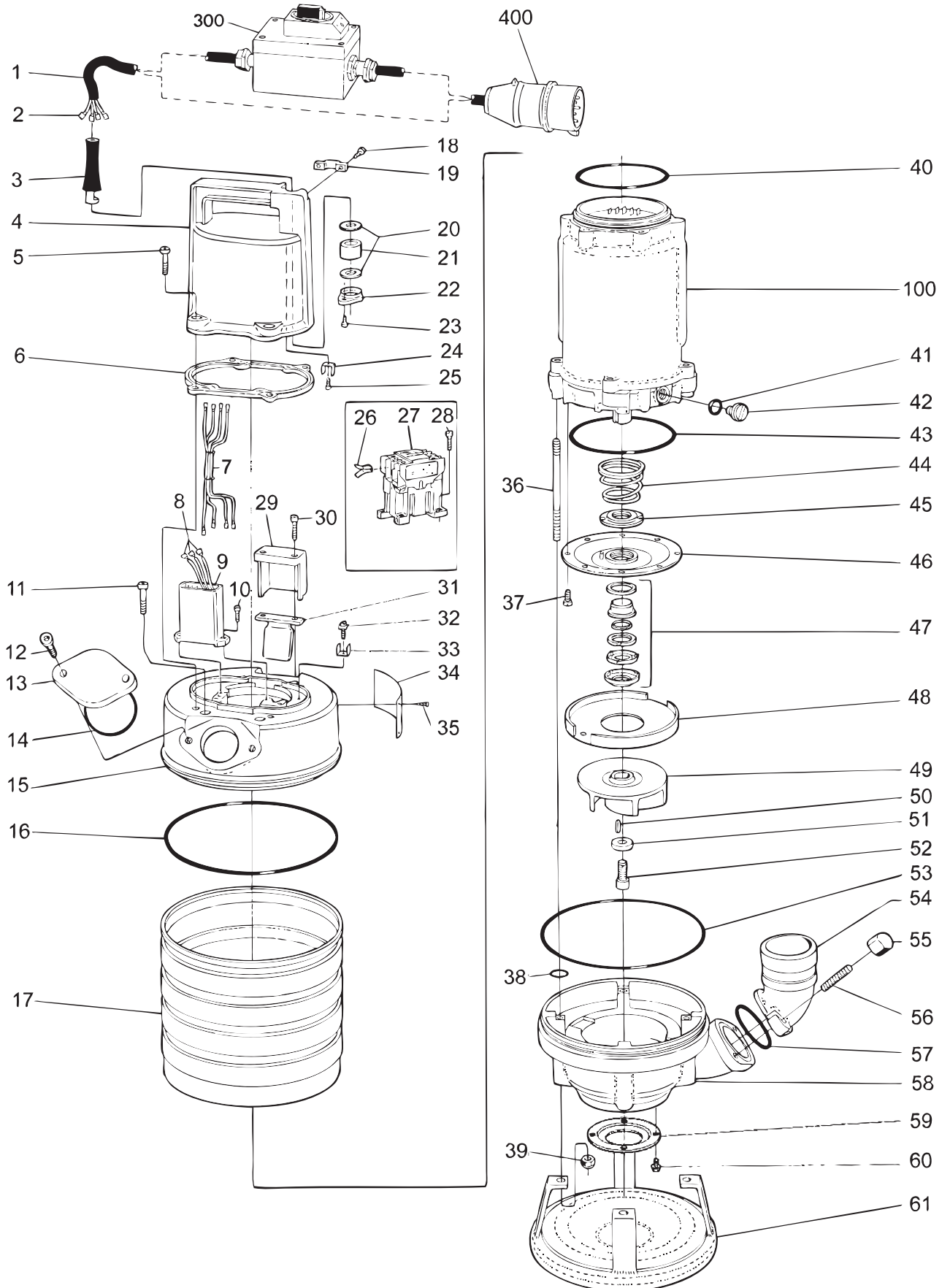

www.grindex.com

SALVADOR INOX



Motorenhet	Motor unit	Motoreinheit	Moteur complet
------------	------------	--------------	----------------

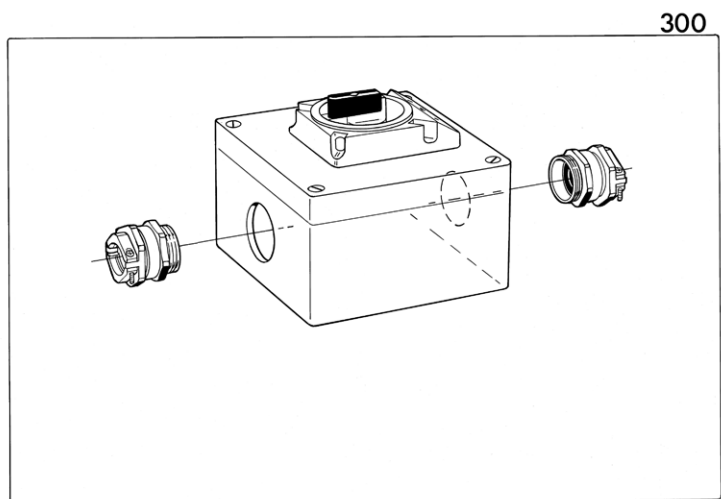
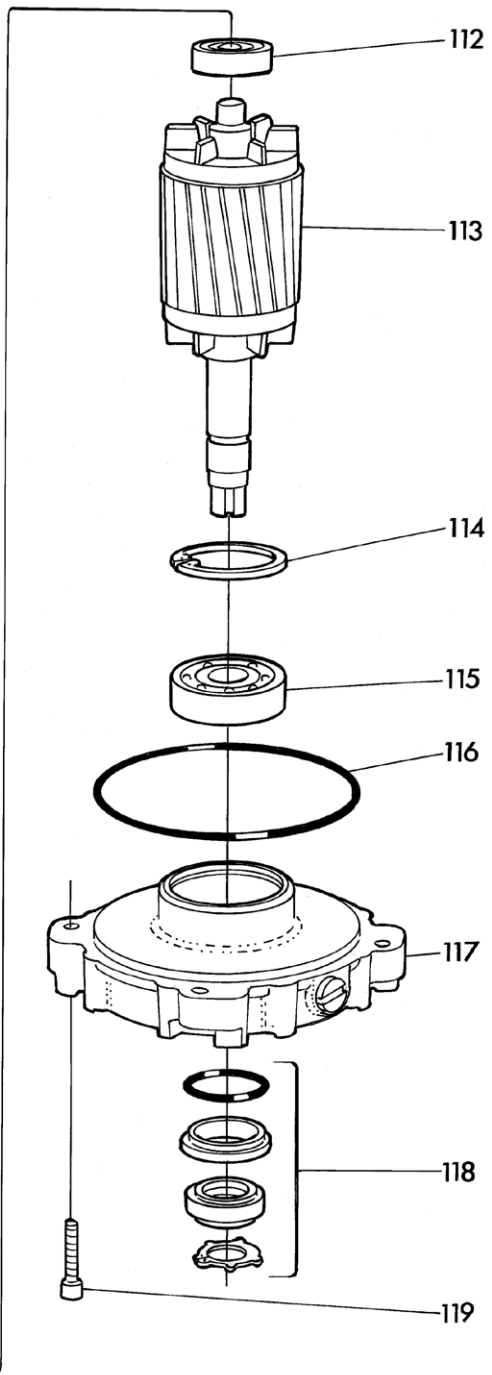
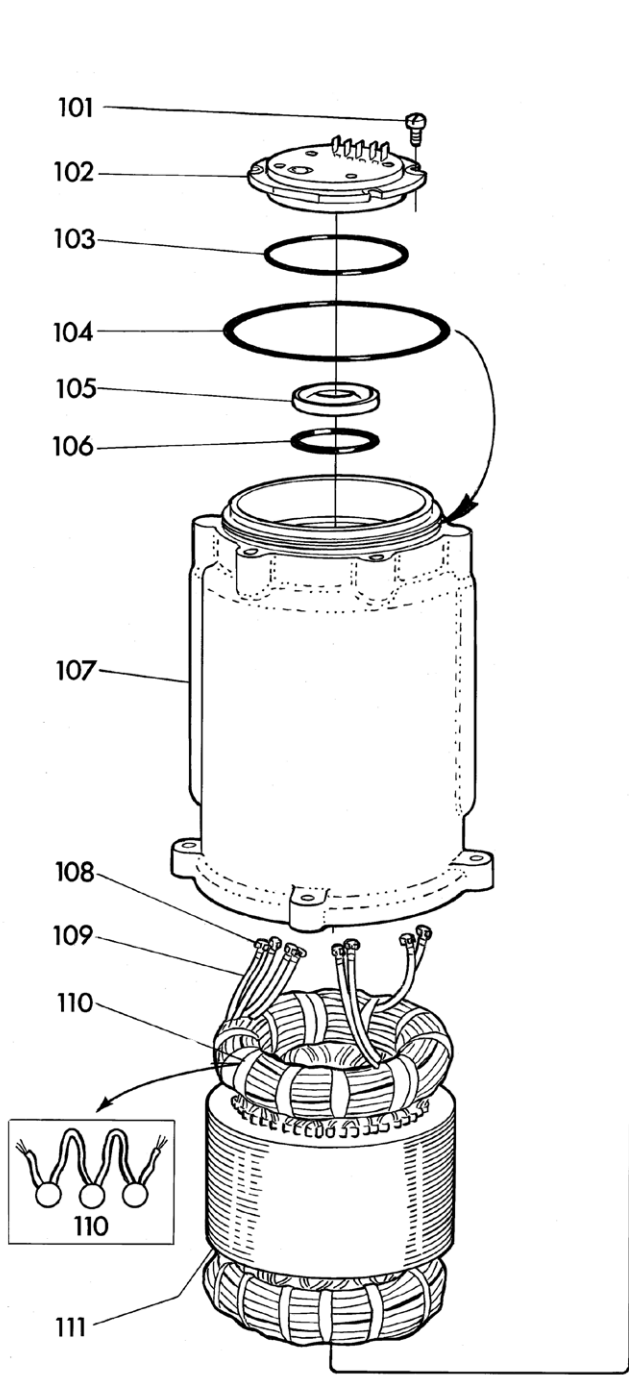

Reservdelista	Spare Parts List	Ersatzteilliste	Liste des pièces de rechange
---------------	------------------	-----------------	------------------------------

Salvador Type 8118.280

3-fas	3-phase	D	Triphasé
-------	---------	---	----------

PU Polyurethan Polyurethane Polyurethan Polyuréthane	RF Rostfritt stål Stainless steel Rostfreier Stahl Acier inoxydable	VJ Vitjärn White iron Chromlegierter Hartguss Fonte blanche alliée au chrom
---	--	--

Pos. nr.

Item No. Detalj nr. Antal

Pos.-Nr. Part No. Quantity

No. de Bestell-Nr. Anzahl

repérag No de pièce Benämning Denomination Bezeichnung Désignation Nombre

1		Kabel	Cable	Kabel	Câble	1
	131 040	4x1,5mm ² (Subcab Ø10,5-11,5) 20m	230-575V			
	131 039	4x2,5mm ² (Subcab Ø12,5-13,5) 20m	380-575V			
		Gäller upp till 20m längd. Vid annan längd kontakta Grindex.	Refers to length of 20m. For other lengths please contact Grindex.	Bezieht sich auf Länge von 20 Metern. Für andere Längen bitte fragen Sie Grindex.	Concernant longueur de 20 metres. Pour autres longueurs consultez Grindex.	
2	50 040 03	Flatstiftshylsa	Receptacle	Steckhülse	Clip	4
3		Kabelböjskydd	Cable entry sleeve	Hülse für Kabeleinführung	Douille d'entrée de câble	
	50 428 00	För Ø9,5-12mm	For Ø9,5-12mm	Für Ø9,5-12mm	Pour Ø9,5-12mm	(1)
	50 428 01	För Ø12-13,8mm	For Ø12-13,8mm	Für Ø12-13,8mm	Pour Ø12-13,8mm	(1)
4	50 709 00	Lock	Cover	Deckel	Couvercle	1
5	50 021 30	Skruv M8x25	Screw	Schraube	Vis	4
6	50 038 01	Planpackning	Gasket	Dichtung	Garniture	1
7	50 035 01	Kabelhärva	Conductors, set	Leitungen, Satz	Conducteurs, compl	1
8	50 203 00	Gaffelkabelsko	Spade terminal	Gabelkabelschuhe	Cosse	4
9		Motorskydd	Motor protector	Motorschutzschalter	Disjoncteur disjoncteur	1
	50 Hz		60 Hz			
	50 034 01	340-460V	50 034 04	340-460V		
	50 034 02	500-575V	50 034 05	500-575V		
10	50 018 00	Skruv M4x12	Screw	Schraube	Vis	2
11	50 021 30	Skruv M8x25	Screw	Schraube	Vis	4
12	50 022 17	Skruv M10x25	Screw	Schraube	Vis	2
13	50 723 00	Inspektionslock	Inspection cover	Deckel	Couvercle	1
14	50 037 08	O-ring 56x5.34	O-ring	O-Ring	Anneau torique	1
15	50 738 00	Överdel	Main cover	Hauptdeckel	Couvercle principal	1
16	50 037 14	O-ring 209.14 x 3.53	O-ring	O-Ring	Anneau torique	1
17	50 063 03	Mantel	Outer casing	Aussenmantel	Enveloppe extérieure	1
18	50 019 05	Skruv M5x18	Screw	Schraube	Vis	2
19	50 725 00	Kabelavlastning	Cable clamp	Zugentlastung	Collier	1
20		Tättningsbricka för kabel:	Washer, for cable:	Scheibe, für Kabel:	Rondelle, pour câble:	2
	50 016 13	Ø10-12mm (Ø0.39-0.47in)				
	50 016 14	Ø12-14mm (Ø0.47-0.55in)				
21		Gummikuts	Rubber seal	Gummidichtung	Manchon, pour câble:	1
	50 015 00	Ø10-12mm (Ø0.39-0.47in)				
	50 015 01	Ø12-14mm (Ø0.47-0.55in)				
22	50 726 00	Införingsfläns	Cable entry flange	Kabeleinführungsflansch	Bride d'entrée de câble	1
23	50 019 05	Skruv M5x18	Screw	Schraube	Vis	2

Item No.	Part No.	Benämning	Denomination	Bezeichnung	Désignation	Quantity
24	50 119 00	Flatstiftsbleck	Tab	Flachstecker	Ian guette	1
25	50 018 01	Skruv M4x8	Screw	Schraube	Vis	1
26	50 120 01	Flatstiftsbleck	Tab	Flachstecker	Ian guette	3
27		Kontaktor	Contacteur	Kontaktor	Contacteur	1
	50 Hz		60 Hz			
	50 353 01	380-415V	50 353 06	460V		
	50 353 03	500-550V	50 353 03	575V		
28	50 018 00	Skruv M4x12	Screw	Schraube	Vis	4
29	50 722 00	Ventillock	Valve cover	Ventildeckel	Couvercle de soupape	1
30	50 019 05	Skruv M5x18	Screw	Schraube	Vis	2
31	50 013 00	Ventil	Valve	Ventil	Soupape	1
32	133 525	Skruv	Screw	Schraube	Vis	1
33	50 119 00	Flatstiftsbleck	Tab	Flachstecker	Ian guette	1
34		Dataskylt	Data plate	Datenschild	Plaque signal	1
	50 907 02	(EU)				
	50 907 03	(US)				
35	410 393	Nit	Rivet	Niet	Rivet	4
36	50 021 35	Pinnskrub M8x137	Stud	Stiftschraube	Goujon	4
37	50 020 18	Skruv M6x16	Screw	Schraube	Vis	8
38	50 037 67	O-ring 8.0 x 3.0	O-ring	O-Ring	Anneau torique	4
39	50 021 36	Mutter M8	Nut	Mutter	Ecrou	4
40	50 037 07	O-ring 117.5 x 5.34	O-ring	O-Ring	Anneau torique	1
41	50 037 13	O-ring 12.37 x 2.62	O-ring	O-Ring	Anneau torique	1
42	50 705 00	Oljeskrub	Oil screw	Ölschraube	Vis d'huile	1
43	50 037 15	O-ring 134.5 x 3.0	O-ring	O-Ring	Anneau torique	1
44	50 559 01	Fjäder	Spring	Feder	Ressort	1
45	50 740 00	Tryckplatta	Thrust plate	Druckscheibe	Rondelle	1
46	50 581 01	Oljehusbotten	Oil housing bottom	Ölgehäuseboden	Fond de carter à huile	1
47	50 789 00	Axeltätningssats, undre	Shaft seal kit, lower	Wellendichtung, unt.,Satz	Joint mécanique, inf. jeu	1
48	50 704 00	Styrplåt	Guide plate	Steuerblech	Plaque de recouvrement	1
49		Pumphjul	Impeller	Laufrad	Turbine	
	50Hz		60HZ			
	50 803 00	Ø120 mm RF	50 803 01	Ø109mm (4.29 in) RF		1
50	50 205 03	Plattkil 5x5x14	Key 5x5x14	Keil 5x5x14	Clavette 5x5x14	1
51	50 022 27	Bricka	Washer	Scheibe	Rondelle	1
52	133 148	Skruv	Screw	Schraube	Vis	1
53	50 037 64	O-ring 216.0 x 3.0	O-ring	O-Ring	Anneau torique	1
54		Tryckanslutning	Discharge conn.	Druckanschluss	Coude de refoulement	1
	50 733 00	DN 75, Hose 3"				
	50 733 01	DN 75, ISO G3A outer				
	50 733 02	DN 75, NPT 3-8 outer				
55	50 022 25	Mutter M10	Nut	Mutter	Ecrou	2
56	50 022 21	Pinnskrub	Stud	Stiftschraube	Goujon	2
57	50 037 08	O-ring 56,52 x 5,34	O-ring	O-Ring	Anneau torique	1
58	50 716 00	Pumphus	Pump housing	Pumpengehäuse	Corps de pompe	1
59	132 739	Fästring	Holder Ring	Haltring	Anneau de serrage	1

Item No.	Part No.	Benämning	Denomination	Bezeichnung	Désignation	Quantity
60	410 396	Skruv M6x10	Screw	Schrube	Vis	4
61	50 706 00	Stödenhet	Stand	Ständer	Pied	1
100		Motorenhet	Motor unit	Motoreinheit	Moteur complet	
101	50 021 31	Skruv M 8x10	Screw	Schraube	Vis	4
102	50 009 00	Kopplingsplint	Terminal board	Klemmenbrett	Plaque à bornes	1
103	50 037 27	O-ring 74.61x3.53	O-ring	O-Ring	Anneau torique	1
104	50 037 09	O-ring 119.5x3.0	O-ring	O-Ring	Anneau torique	1
105	140 365	Täckbricka	Protection cover	Schutzdeckel	Couvercle de protecteur	1
106	50 037 11	O-ring 39,69x3,53	O-ring	O-Ring	Anneau torique	1
107	50 711 00	Statorhus	Stator housing	Statorgehäuse	Logement de stator	1
108		Flatstifthylsa/ serieskarv	Receptacle/ joining tube	Steckhülse / Verbindung	Clip/ connexion	
	50 040 03	Flatstift	Solderless lug	Flachsteckkontakt	Pris contact plat	5-11
	410 034	Serieskarv 460V endast 9-ledare	Joining tube 460V only 9-leads	Verbindung 460V nur 9-Leiter	Connexion 460V 9-conducteurs seules.	3
109	50 079 00	Systoflexrör 40 mm	Insulating tube	Isolierschlauch	Gaine isolante	3
110	50 039 01	Termokontakt	Thermal contact	Thermokontakt	Contact thermique	1
111		Stator	Stator	Stator	Stator	1
	50 Hz		60 Hz			
	50 042 05	220-230/380-415V	50 042 14	230/460V 9-leads		
	50 042 09	500-550V Y	50 042 16	575V Y		
112	140 362	Kullager, övre	Ball bearing, upper	Kugellager, oberes	Roulement à billes sup.	1
113	50 729 00	Rotorenhet	Rotor unit	Rotoreinheit	Rotor complet	1
114	140 064	Låsring SgH 62	Circlip	Nutring	Circlip	1
115	140 363	Lager, undre	Ball bearing, lower	Kugellager, unteres	Roulement à billes inf.	1
116	50 037 16	O-ring 144,5x3.0	O-ring	O-Ring	Anneau torique	1
117	50 713 00	Lagerhållare	Bearing holder	Lagerhalter	Logement de roulement	1
118	50 534 00	Axeltätningssats, övre	Shaft seal kit, upper	Wellendichtung, ob.,Satz	Joint mécanique, sup. jeu	1
119	50 021 28	Skruv M8x35	Screw	Schraube	Vis	4
200		Startutrustning	Starter Kit	Starter-Installationssatz	Kit De Démarreur	
	50 Hz		60 Hz			
	50 820 00	400V DOL	50 820 05	460V DOL		
	50 820 02	500V DOL	50 820 06	575V DOL		
300		Fasväxlare 16A	Phase shifter 16A	Phasenwechsler 16A	Inverseur de phase 16A	(1)
	50 102 00	Ø6-13mm				
301		Kabelavtätning	Cable entry	Kabelverschraubung	Entrée de cable	2
	50 276 02	Ø8-11mm				
	133 841	Ø11-14,5mm				
400		Europahandske	Euro plug	Euro-Verdinder	Euro connecteur	
	50 100 00	CEE 416-6 (380-400V/50Hz)				(1)
	50 100 10	CEE 316-7 (500V/50Hz)				(1)

Item No.	Part No.	Benämning	Denomination	Bezeichnung	Désignation	Quantity
50 085 14	O-ringsats,	Set of O-rings, bestående av:	O-Ringsatz, comprising:	Anneaux toriques, bestehend aus:	jeu comprenant:	1
6	50 038 01	(1)	43	50 037 15 (1)		
14	50 037 08	(2)	53	50 037 14 (1)		
16	50 037 14	(1)	103	50 037 27 (1)		
38	50 037 67	(4)	104	50 037 09 (1)		
40	50 037 07	(1)	106	50 037 11 (1)		
41	50 037 13	(1)	116	50 037 16 (1)		

Olja	Oil	Öl	Huile	0.30L
Vitolja	White oil	Weißöl	Huile cristalline	
Viskositet ISO VG 15	Viscosity ISO VG 15	Viskosität ISO VG 15	Viscosité ISO VG 15	

Specifications can be changed without notice.



Grindex AB • Box 7025 • 174 07 Sundbyberg • Sweden • Tel +468 606 66 00 • Fax +468 745 53 28 • marketing@grindex.com